

# MASTERPIUMA

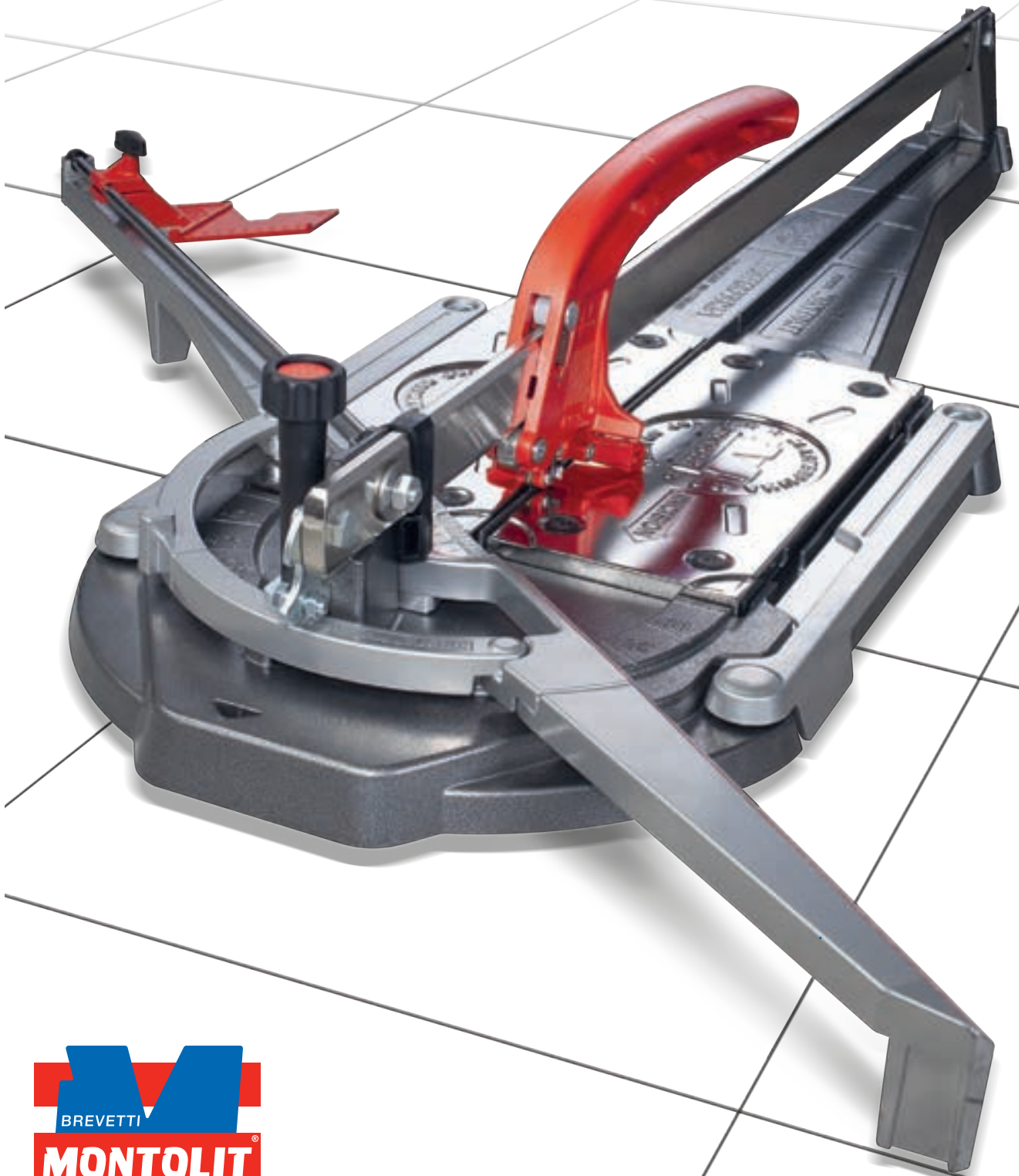

TAGLIAPIASTRELLE PROFESSIONALE • PROFESSIONAL TILE CUTTER



SINCE 1946

# MASTERPIUMA

# 5

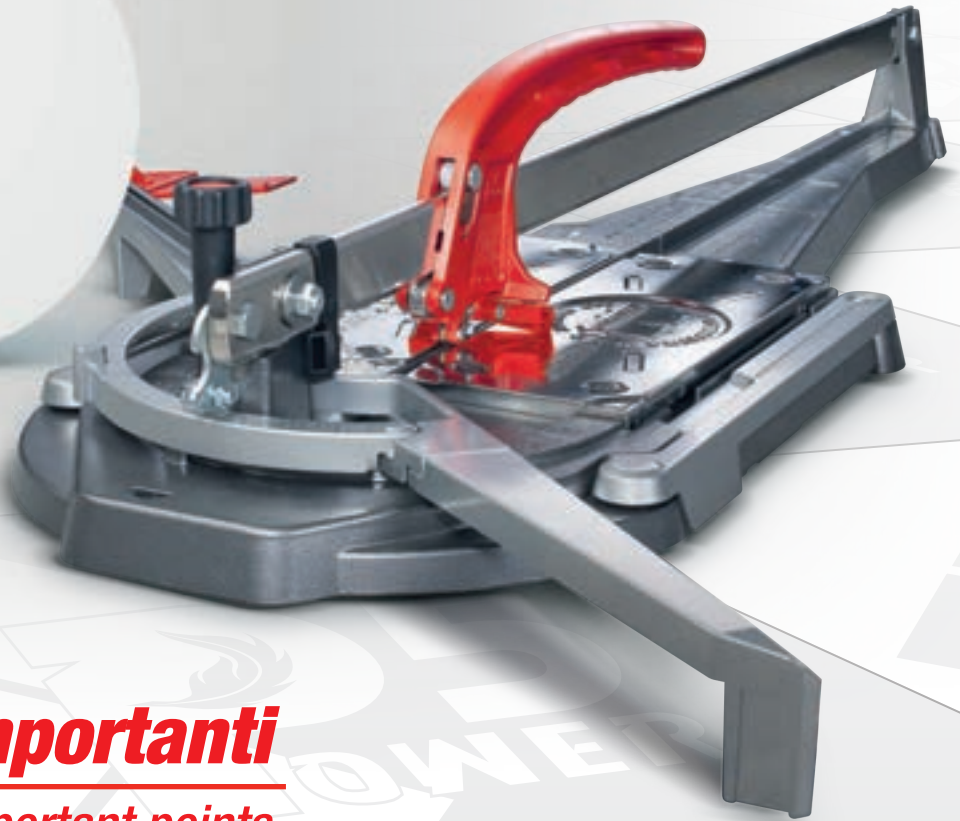

## ***5 punti importanti***

*5 important points*

### **1 TELAILO MODULARE STRUTTURATO**

*Reinforced modular frame*

### **2 SQUADRA MULTIFUNZIONE**

*Multi-functional square*

### **3 SUPPORTI LATERALI**

*Extra large supports*

### **4 INDICATORI DI FORZA**

*Strength indicators*

### **5 PROGETTATA PER GRANDI FORMATI**

*Designed for large formats*

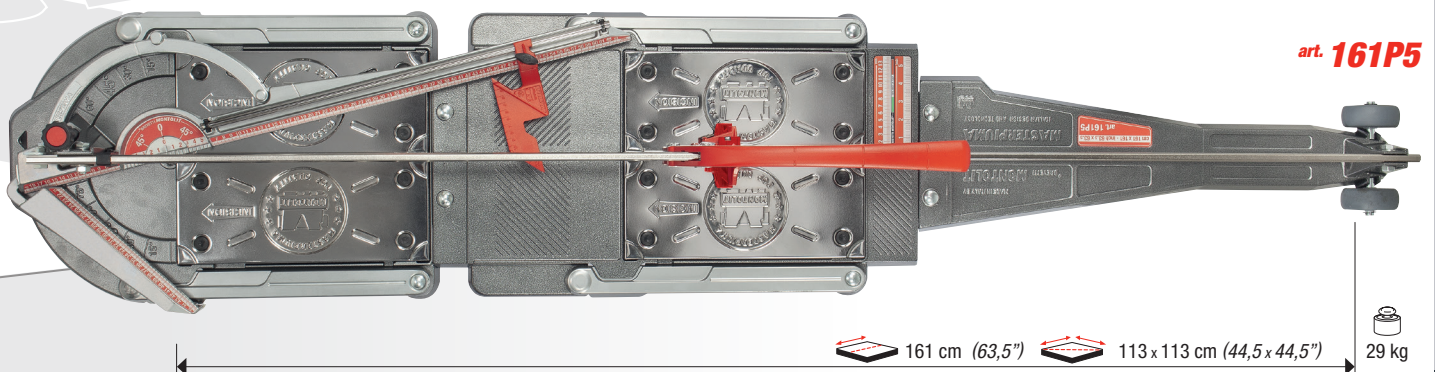
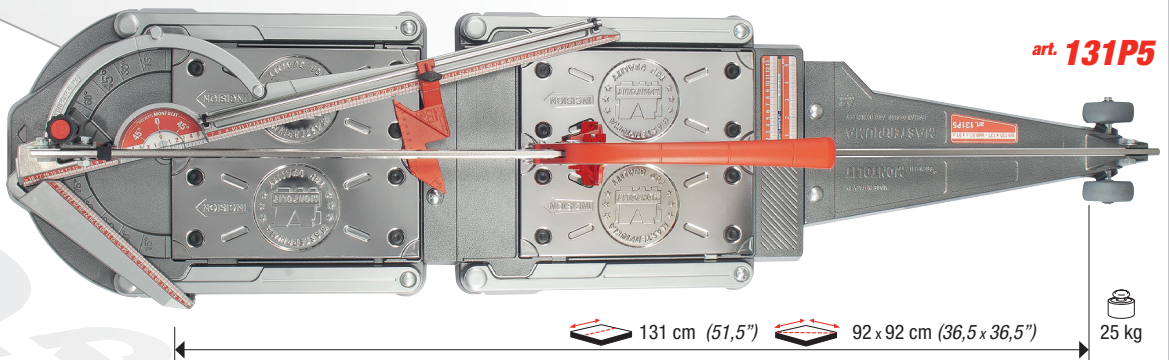
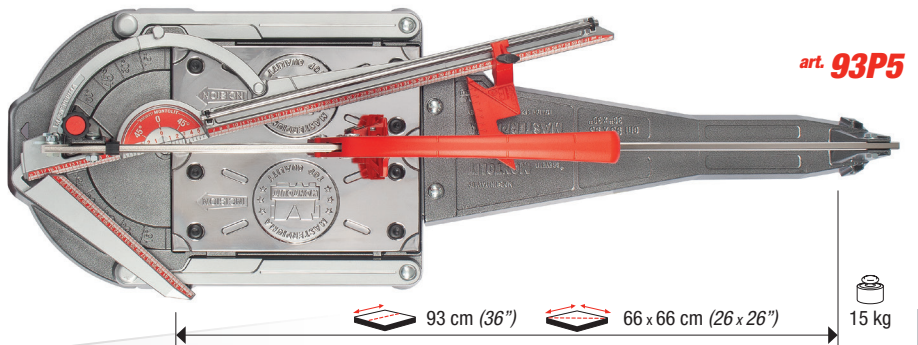
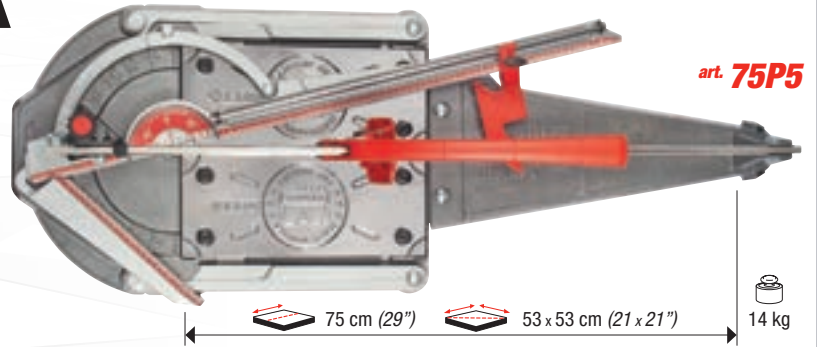
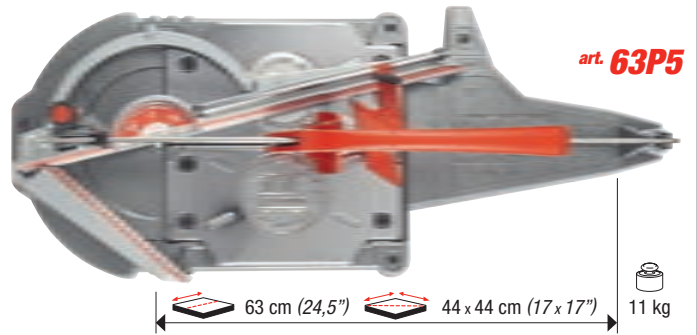

## **SQUADRA MULTIFUNZIONE**

*Multi-functional square*

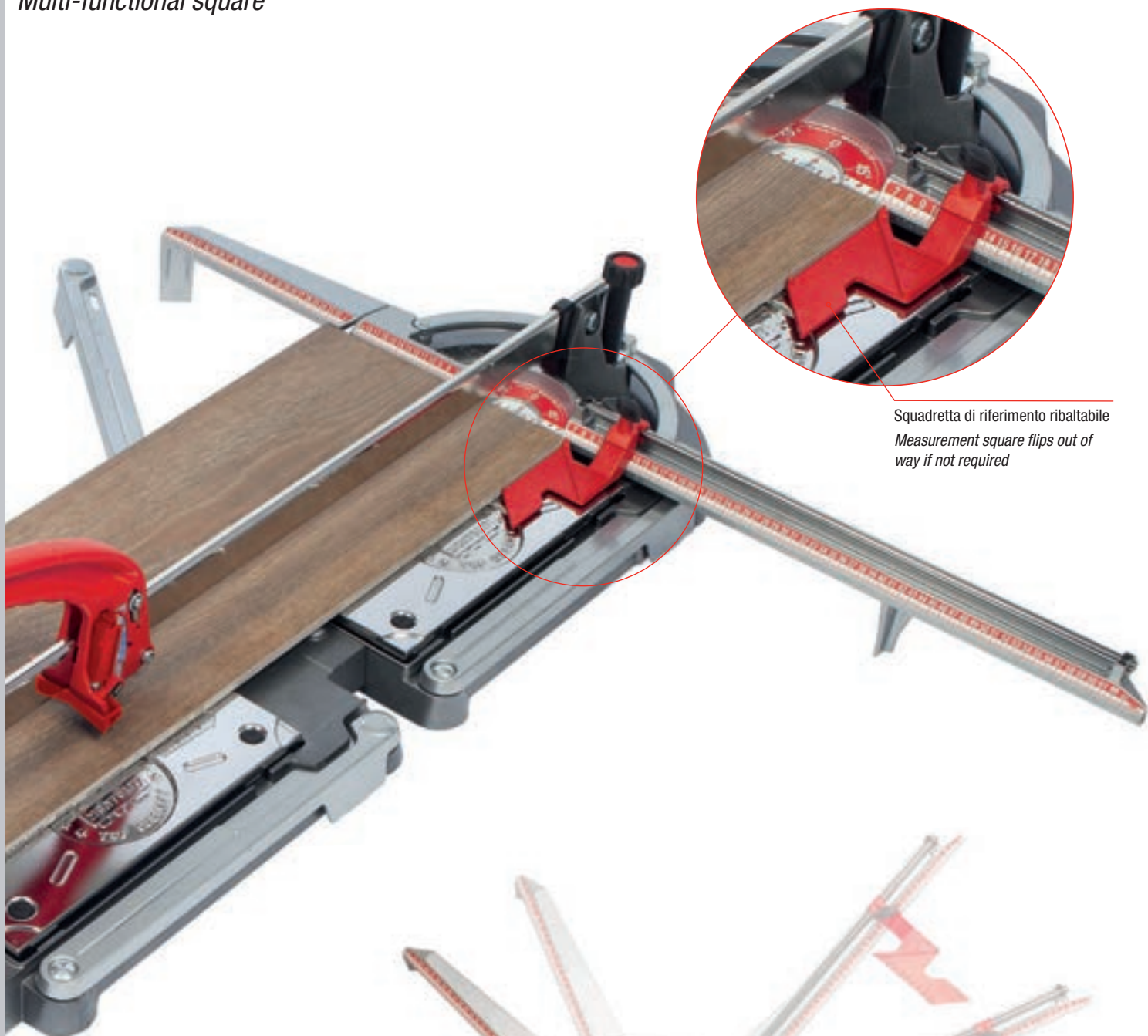

Squadretta di riferimento ribaltabile  
*Measurement square flips out of way if not required*

Rotazione squadra  $-45^{\circ} \div +45^{\circ}$   
*Square rotation  $-45^{\circ} \div +45^{\circ}$*

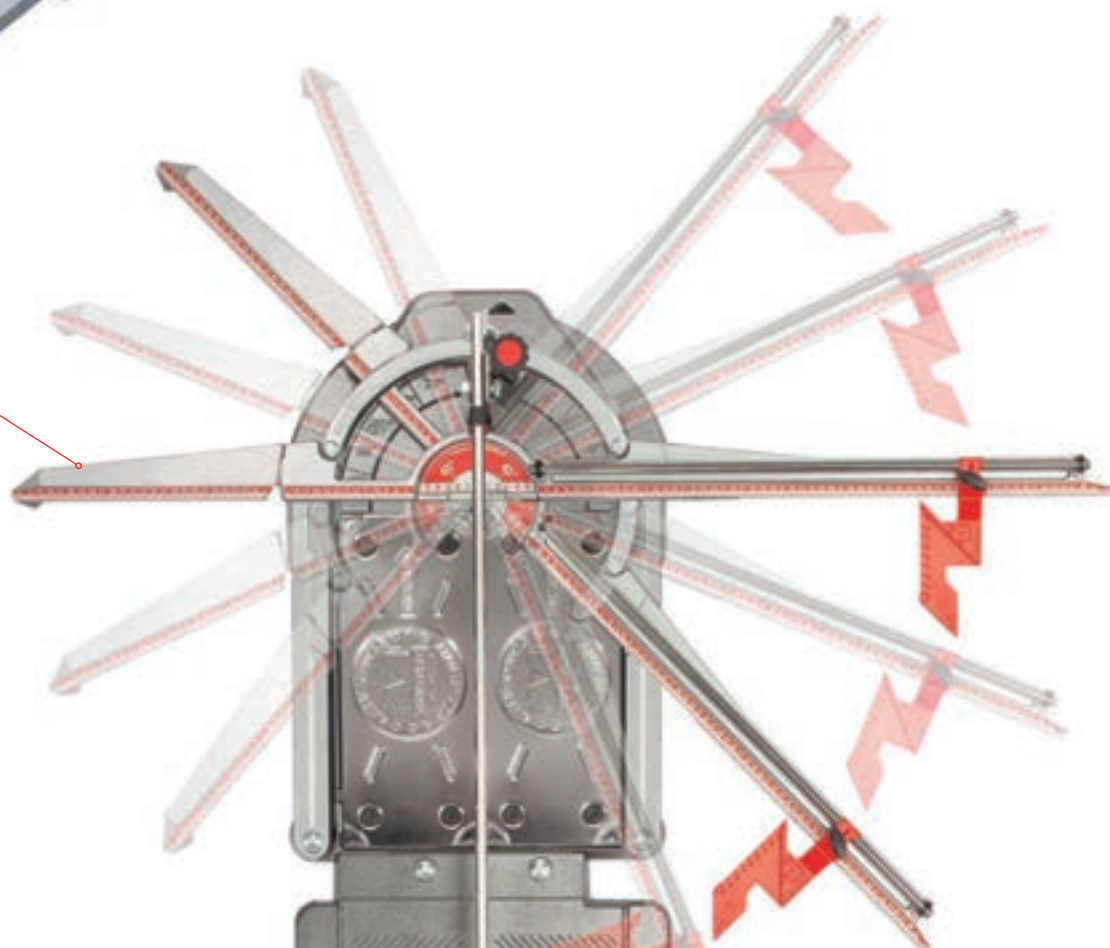

## IMPOSTAZIONE MISURA

Measure setting

90°

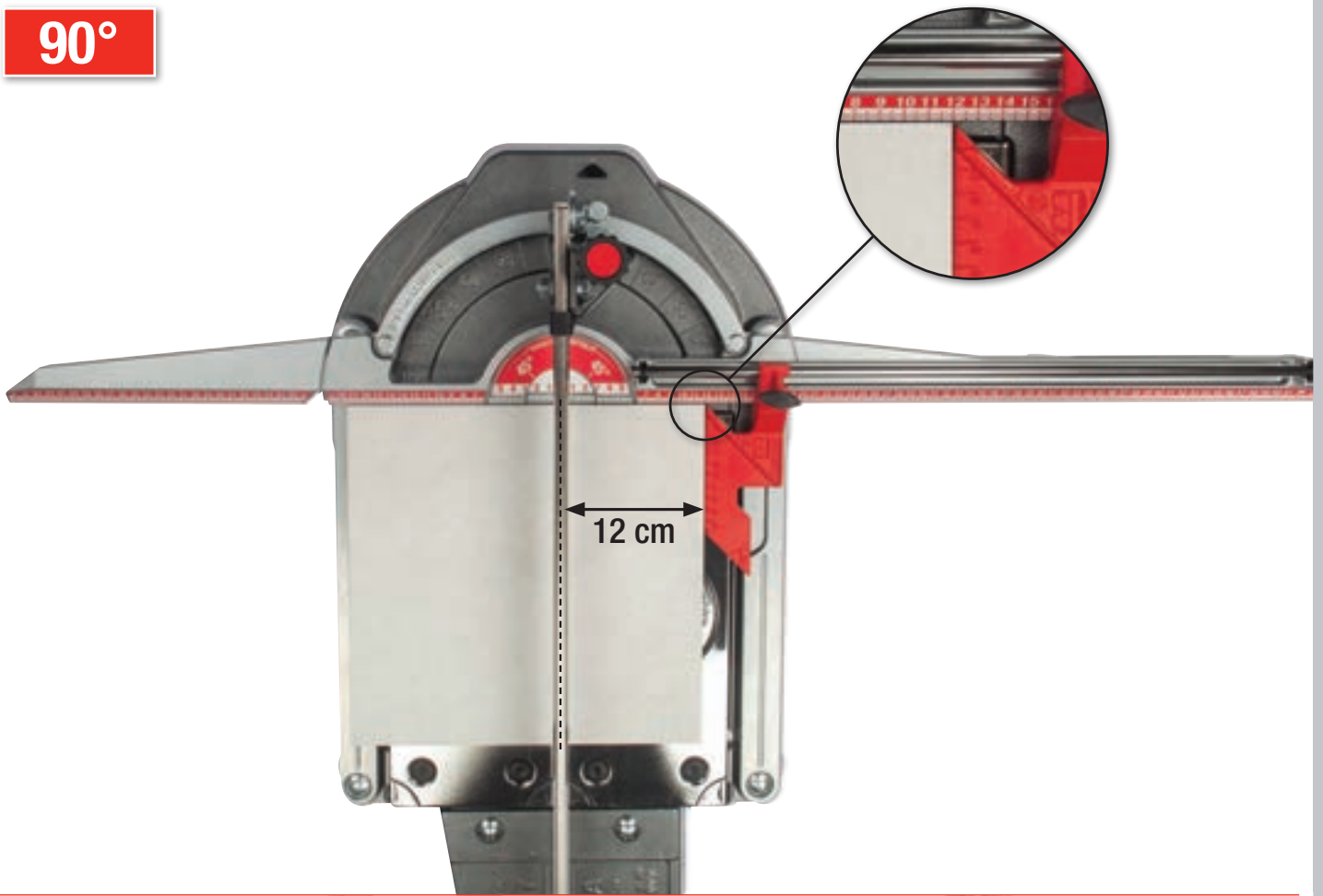

-45° +45°

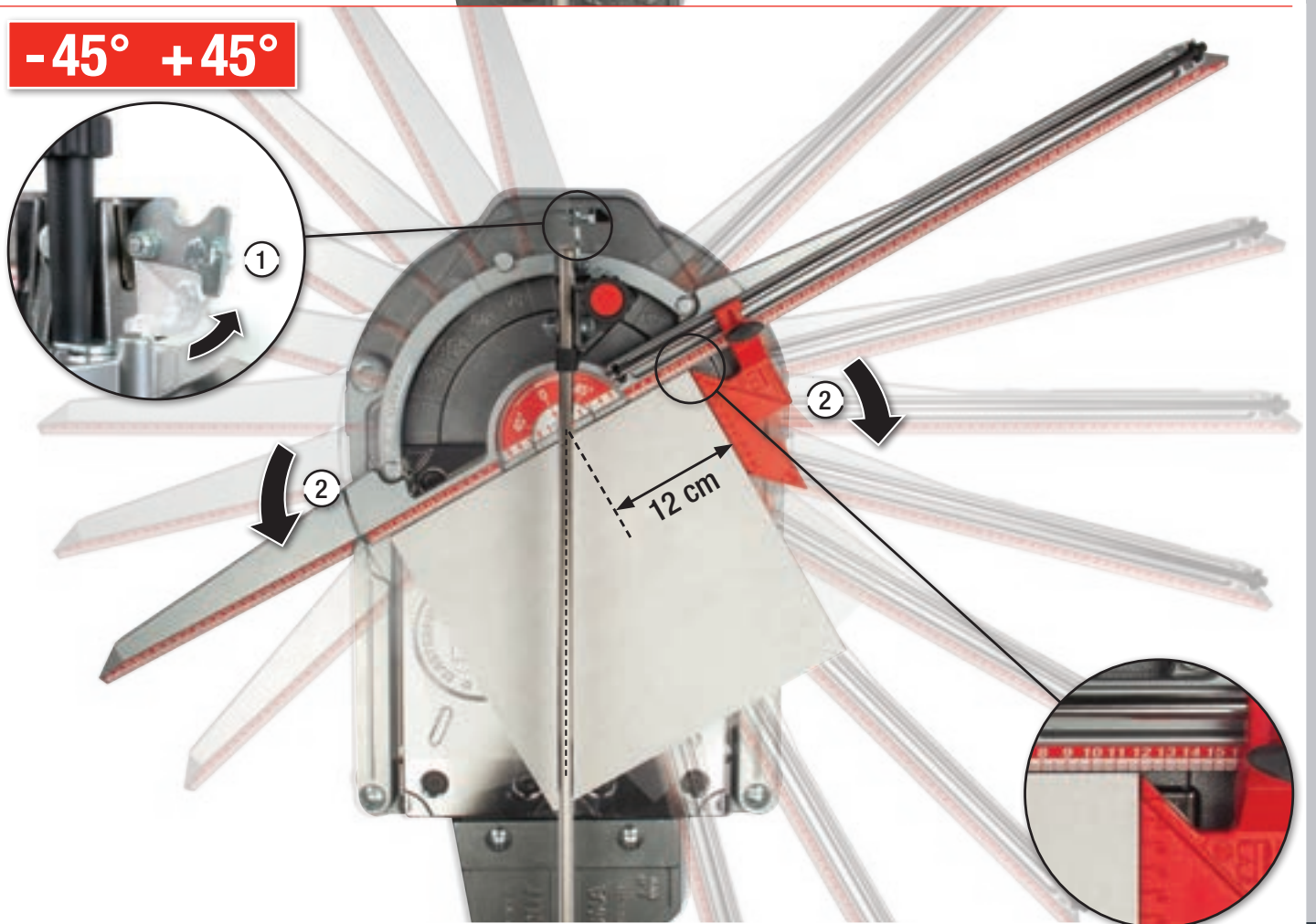

**SUPPORTI EXTRA LARGE** • art. 63P5

*Extra large support*



**2 SUPPORTI LATERALI IN ALLUMINIO** • art. 75P5 - 93P5

*2 Aluminium supports side*



**4 SUPPORTI LATERALI IN ALLUMINIO · art. 131P5 - 161P5**

*4 Aluminium supports side*

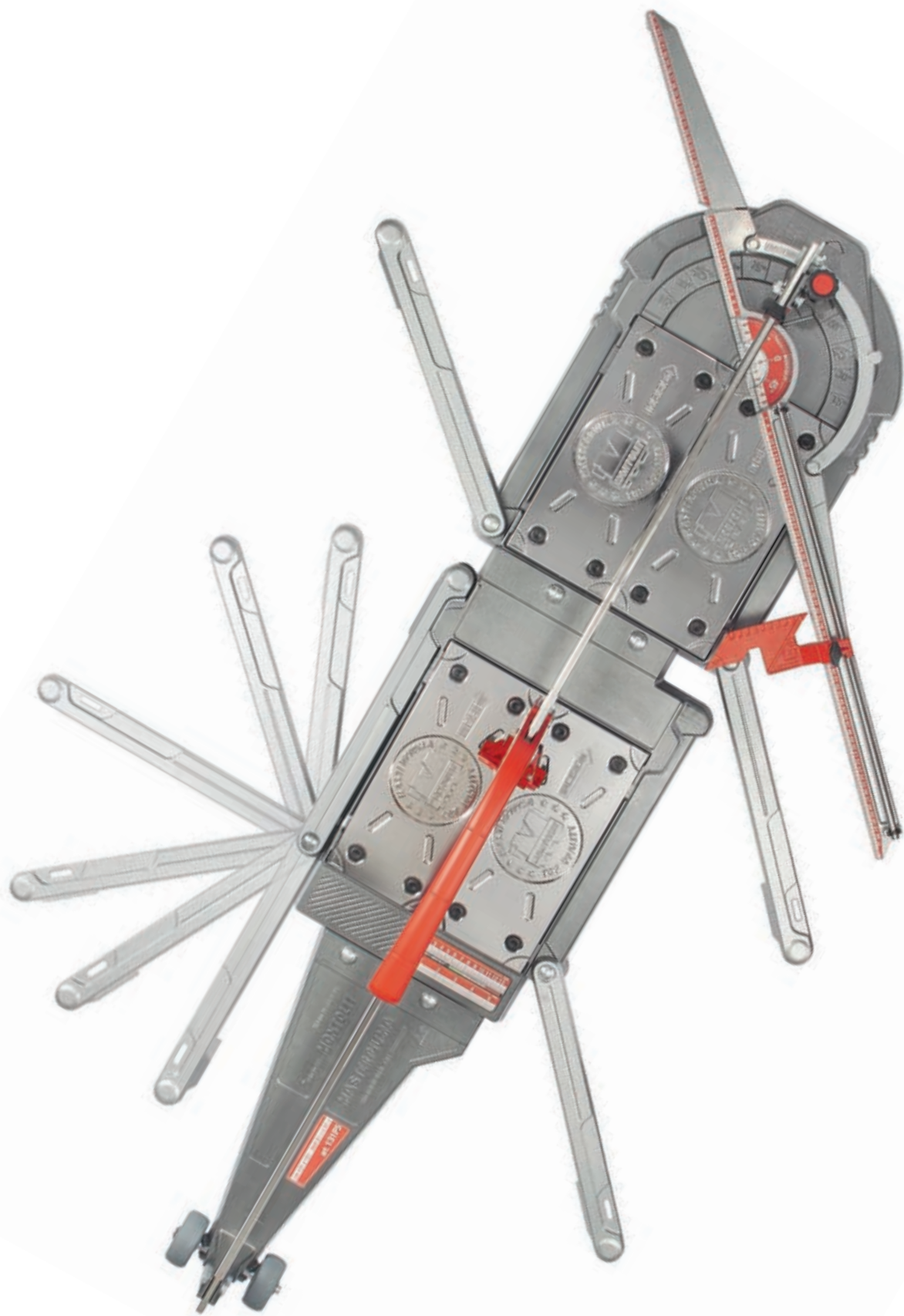

**INDICATORI DI FORZA**

*Strength indicators*

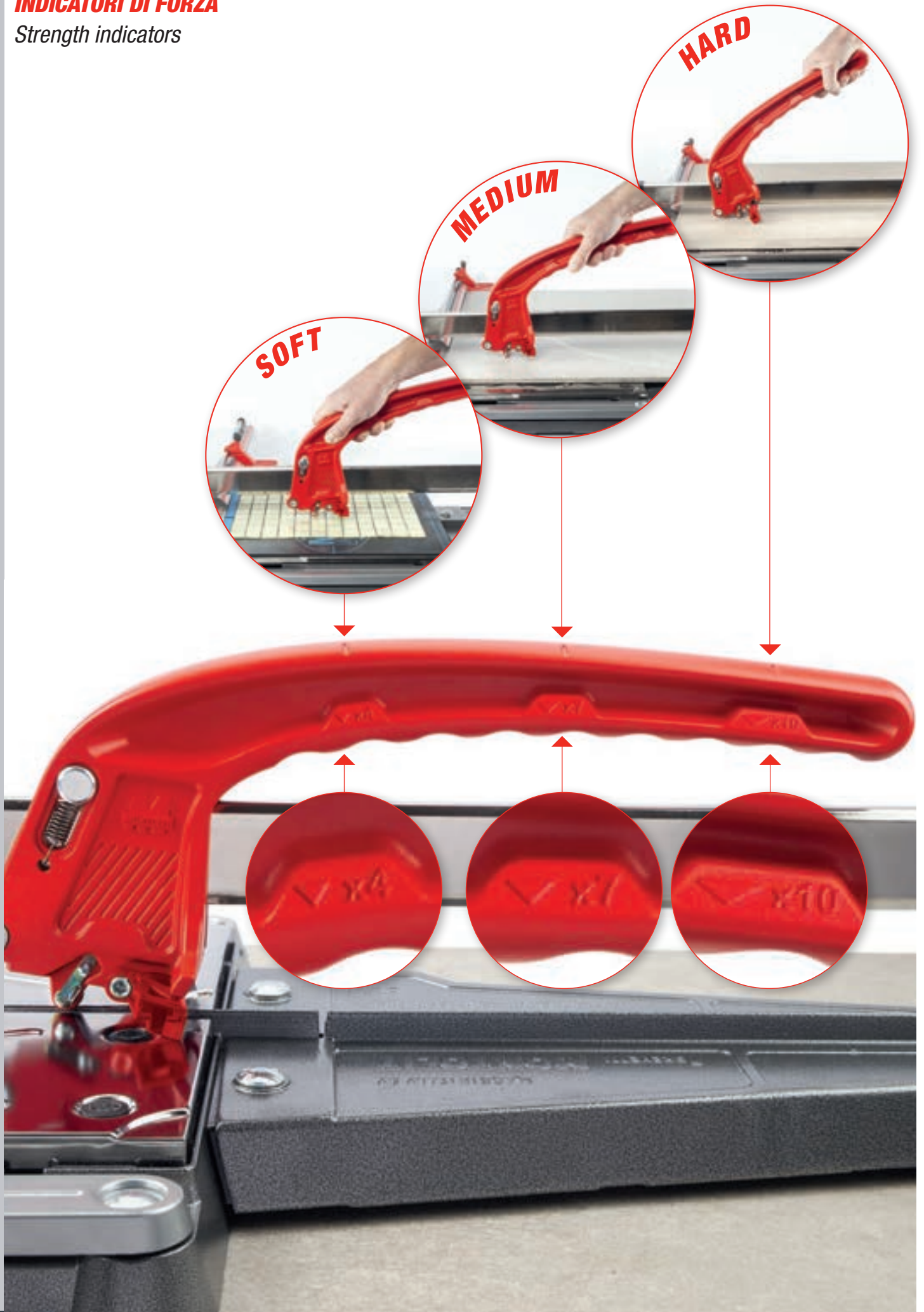



## INSTALLAZIONE FIALA LUBRIFICANTE

Lubricant vial installation

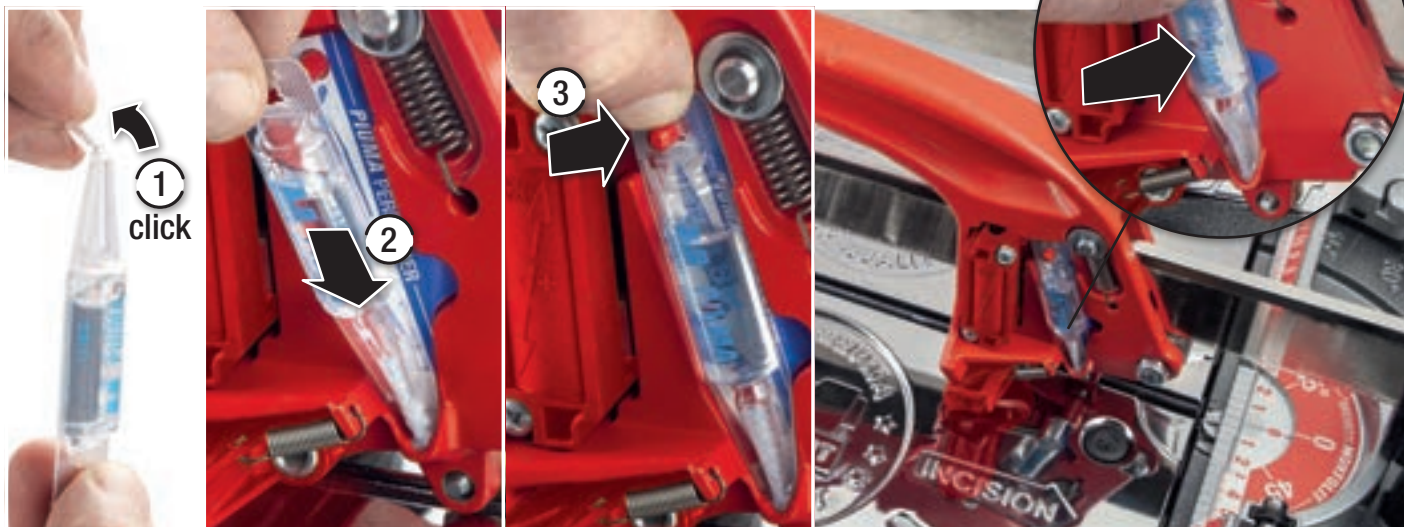

## INCISIONE

Appoggiare la rotella d'incisione sulla piastrella e premere il portarotelle spingendolo verso la squadra.

## SCORING

Put the scoring wheel on to the surface of the tile, press down on the incision handle, and push the scoring wheel towards the measurement guide.



**TAGLIO** • Terminata l'incisione, battere sul portarotelle per lo spacco.

**SPLIT** • When the tile has been scored, tap the incision handle to split the tile.



## OPTIONALS

### VERTIGO2

Supporto per tagliapiastrelle manuali (artt.131P5 e 161P5),  
agevola il taglio in verticale delle piastrelle di grande formato

Support for manual tile cutter (artt.131P5 and 161P5),  
facilitates the vertical cutting of large format tiles



### COVER

Protezione per tagliapiastrelle

Protection for tile cutters



**MOSAKIT** · art. 58

Tappetino in gomma per mosaici, piastrelle in vetro, delicate e sottili (3mm)

*Rubber pad for mosaic tiles, plus delicate and very thin 3mm glass tiles.*

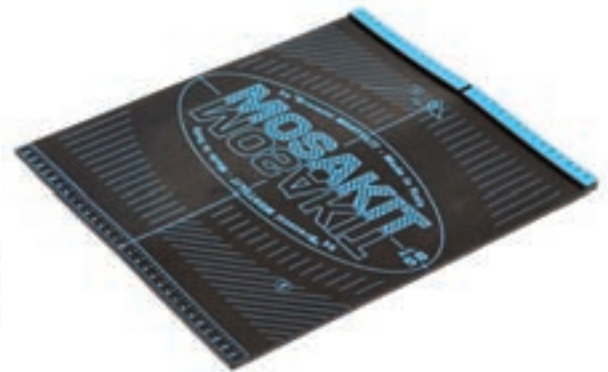
**BASEBOARD** · art. 64

Riferimento aggiuntivo per grandi formati ideale per il taglio di listelli e di battiscopa

*Bracket precision for cutting strip tiles and skirting boards*

**PIEDONE** · art. 449P

Sistema di spacco supplementare per piastrelle di grandi dimensioni e gres porcellanato spessorato

*Additional splitting system for extra large tiles size and porcelain tile thickness*



## REGOLAZIONE DEL PORTAROTELLE

Adjustment of the incision handle



## SOSTITUZIONE DELLA ROTELLA DI INCISIONE

Replacing the incision wheel

**Art. 245 - STANDARD**



**Art. 245T - TITANIUM**

Special for  
Gres Porcellanato

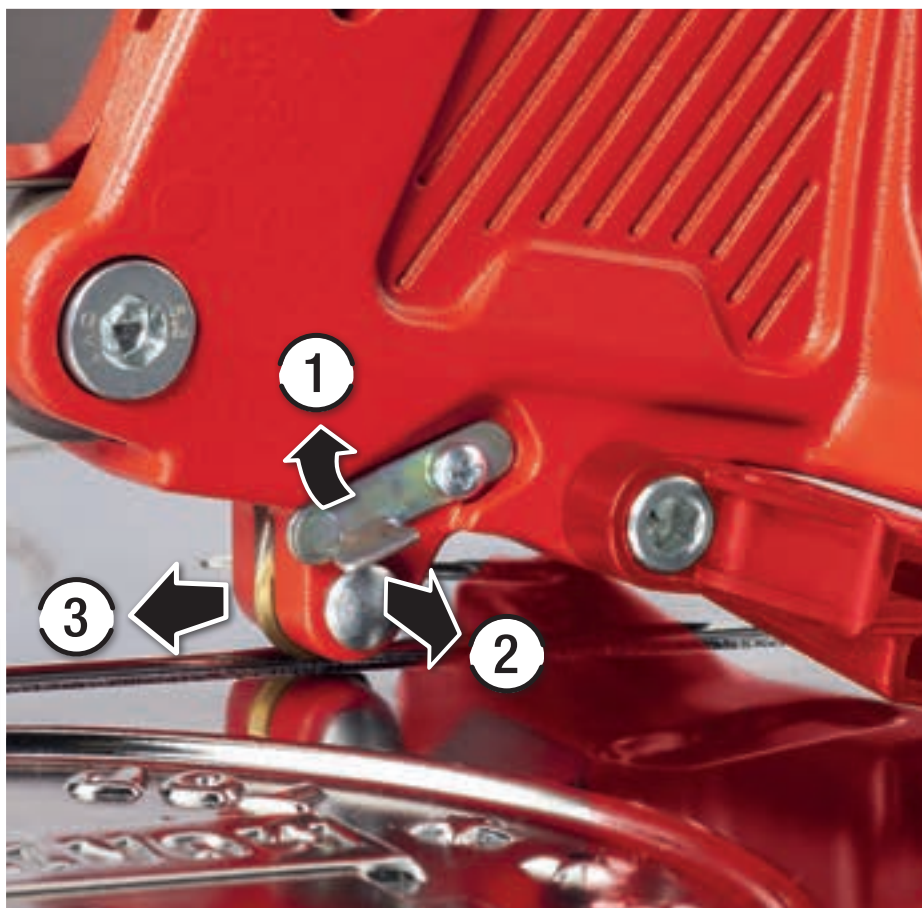

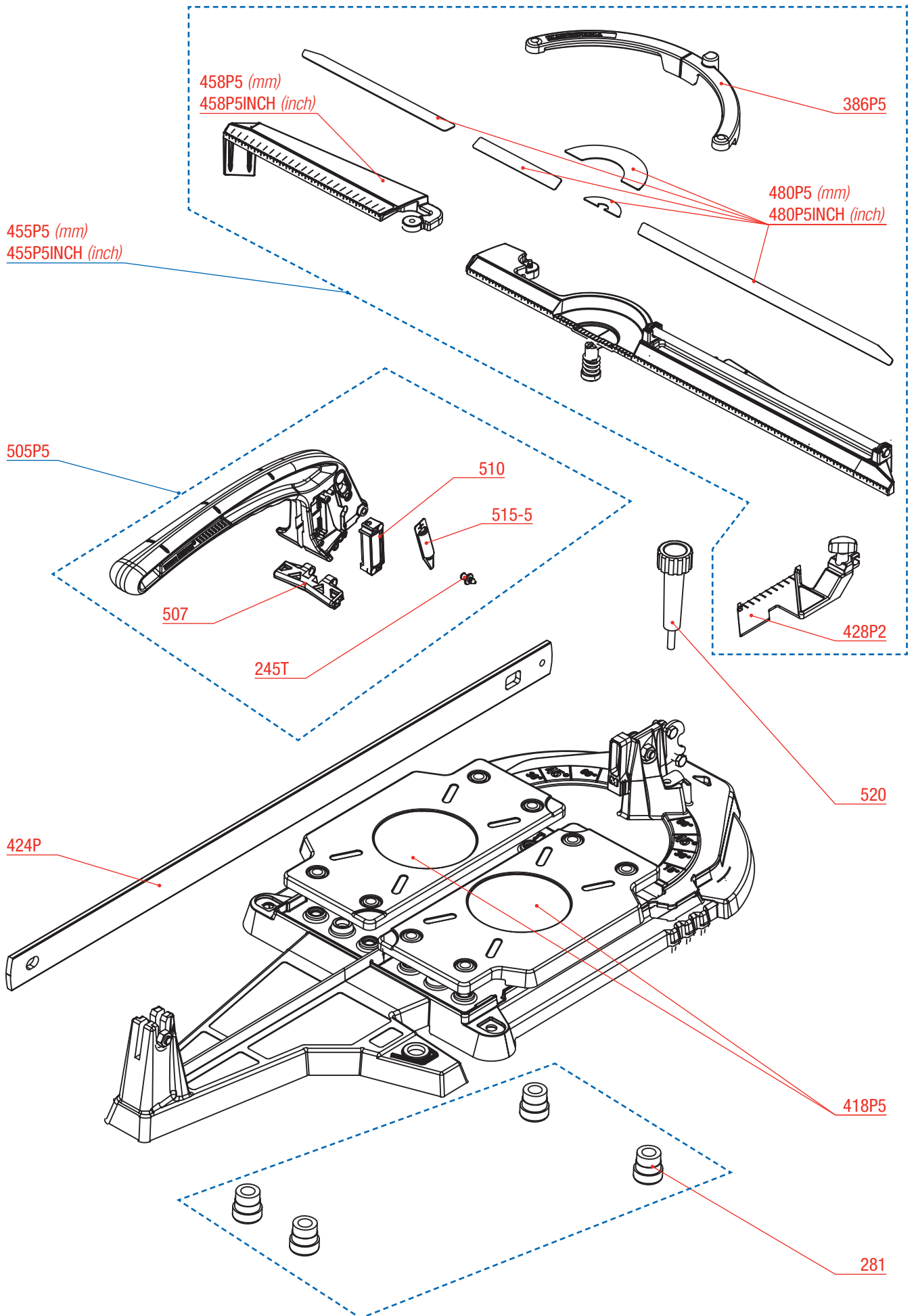

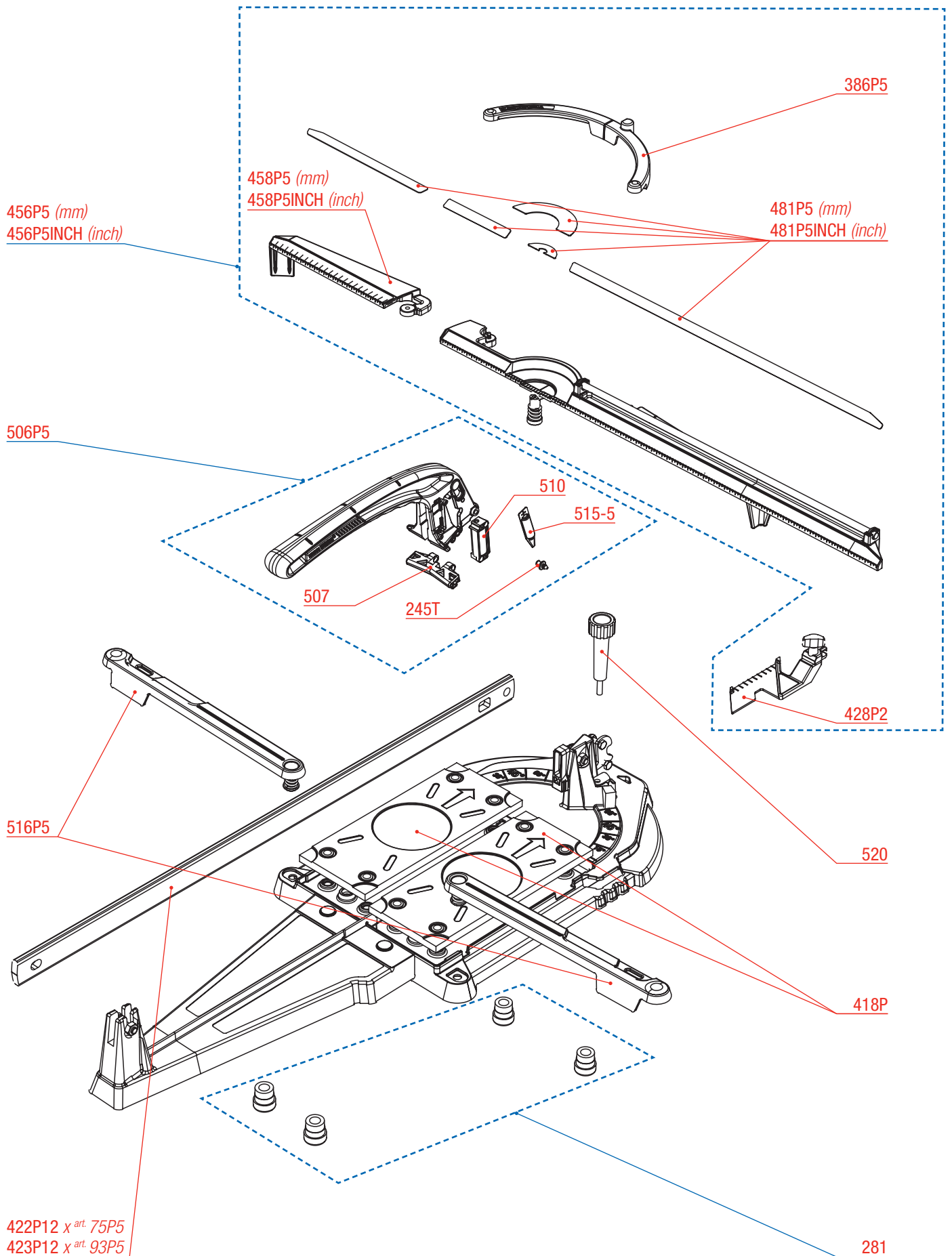

**art. 131P5 · 161P5**

Ricambi · Spare parts

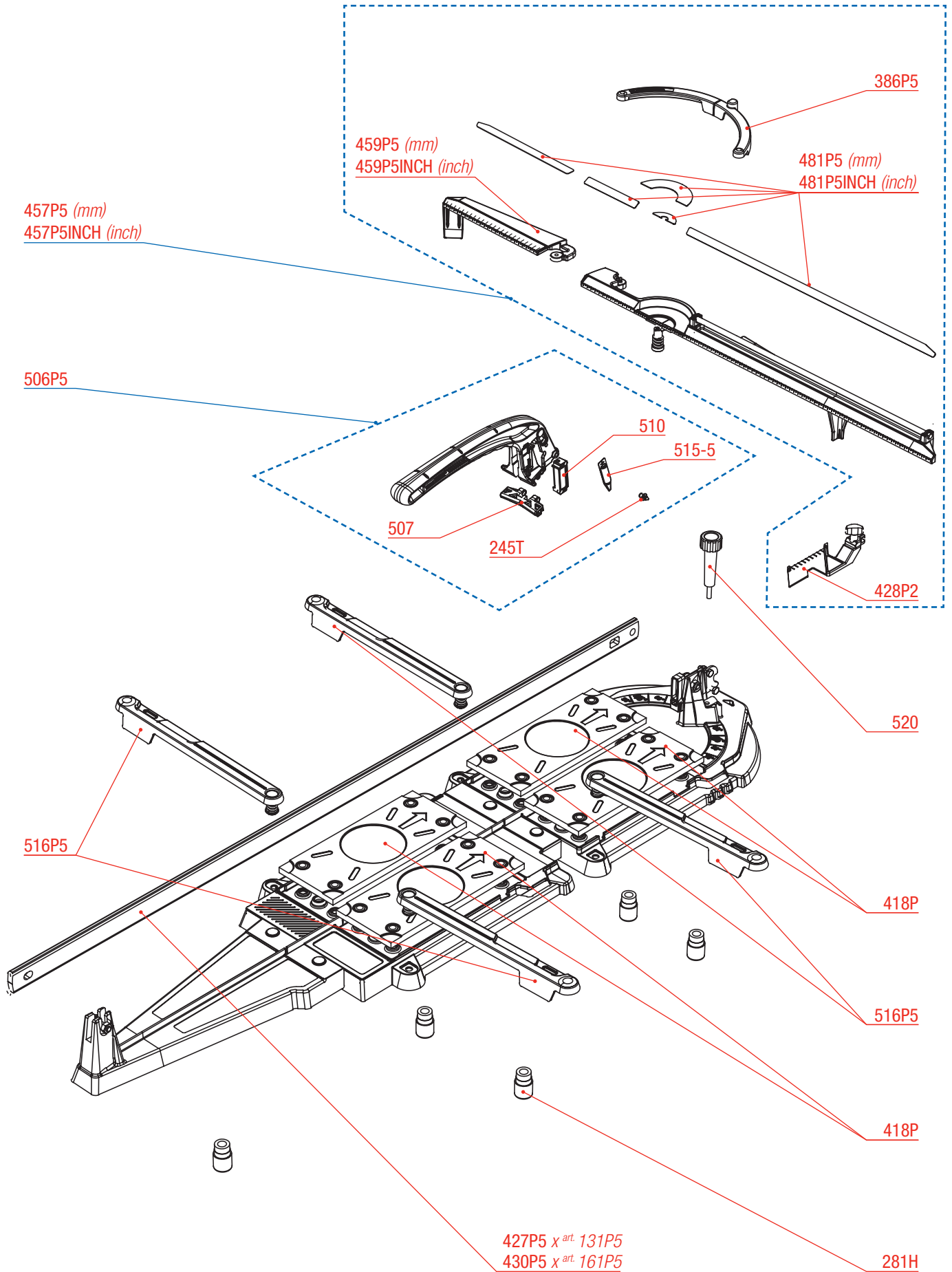

## **T** **GARANZIA**

Tutte le tagliapiastrelle manuali MONTOLIT sono coperte da garanzia a vita (riconosciuta a giudizio esclusivo dell'Ufficio Tecnico della Brevetti MONTOLIT S.p.A.) su eventuali difetti di costruzione. Guasti derivanti da un uso non conforme o da normale usura sono esclusi dalla presente garanzia.

### **Oggetto: Campo di applicazione della Direttiva Macchine (Direttiva 2006/42/CE)**

Portiamo a conoscenza tutti i Ns. clienti che alcuni macchinari prodotti dalla Brevetti **MONTOLIT** S.p.A. non sono soggetti al campo di applicazione della direttiva macchine e conseguente marcatura "CE". Infatti tale direttiva considera nel suo campo di applicazione le macchine, intese come insieme di pezzi o di organi collegati tra loro, di cui almeno uno mobile e la mobilità deve essere prodotta da una fonte di energia esterna, escludendo la forza umana diretta.

Per quanto riguarda l'esclusione delle macchine la cui unica fonte di energia e la forza umana diretta, ci si riferisce in genere ad utensili a mano quali pinze, forbici, trapani a mano, taglierine manuali, ecc., la cui azione termina quando termina l'applicazione della forza umana.

Pertanto solo alcuni degli utensili prodotti dalla Brevetti **MONTOLIT** S.p.A. rientrano nella definizione di macchina come inteso dalla normativa, e sono regolarmente contrassegnati da marcatura "CE" e corredate di tutti i documenti necessari a norma di Legge.

Fanno eccezione particolari utensili non corrispondenti alla famiglia delle macchine, ma appartenenti a particolari tipologie di prodotti oggetto di direttive specifiche che prevedono comunque la marcatura "CE" (es. apparecchi laser ecc.).

Brevetti **MONTOLIT** S.p.A.  
Direzione Tecnica  
Ing. Montoli Stefano

## **GB** **WARRANTY**

All MONTOLIT manual tile-cutters are covered by lifetime warranty (recognisable exclusively by the Brevetti **MONTOLIT** S.p.A. Technical Office) on any manufacturing defects. Breakages resulting from non-conforming or abnormal use are excluded from cover by this warranty.

### **Re: scope of the Machinery Directive (Directive 2006/42/EC Article 1)**

*We would like to make all our customers aware that certain machines produced by Brevetti **MONTOLIT** S.p.A. do not fall within the scope of the Machinery Directive and consequent "CE" marking.*

*As a matter of fact, in its scope, the directive considers machines, designed as a set of parts or components connected together, at least one of which being moves and mobility has to be produced by an external energy source, excluding direct human effort.*

*With regard to the exclusion of machinery whose only power source is directly applied human effort, this generally refers to hand tools such as pliers, scissors, hand drills, manual cutters etc. whose action ends when human effort is no longer applied.*

*As a consequence, only some of the tools produced by Brevetti **MONTOLIT** S.p.A. fall within the definition of machine as intended by the regulation, and have the regular "CE" marking and are accompanied by all documents required under the law.*

*Exceptions are made for special tools which do not correspond to the family of machines, but belong to particular types of products covered by specific directives which nevertheless require the "CE" marking (e.g. laser equipment etc.).*

Brevetti **MONTOLIT** S.p.A.  
Technical Management  
Ing. Montoli Stefano







SINCE 1946

## Brevetti Montolit S.p.A.

Sedi operative/Company headquarters:

Largo Cav. Montoli - 21050 Cantello (VA) Italy

Via Varese 4/A - 21050 Cantello (VA) Italy

Sede legale/Legal head office:

Via Turconi, 25 - 21050 Cantello (VA) Italy

Tel. ++39 0332 419 211

Fax ++39 0332 418 444

[www.montolit.com](http://www.montolit.com)

[info@montolit.com](mailto:info@montolit.com)

*Montolit is technical partner of:*

